

TERMINATOR T2



Owners Handbook Terminator 2 Fan Clutch

- Two Speed Configuration
- Advanced Design – high torque, steel-on-steel cone drive
- Extensively tested in Australian conditions
- Long Service Life
- Low Maintenance

Introduction

The Terminator clutch was developed for a simplistic option for the OE and an upgrade option for the On-highway truck aftermarket. The low part count results in a highly reliable & durable design that lasts longer than any competitors equivalent fan drive.

Travel required for the clutch to reach full engagement is a fifth of the closest competitor, resulting in minimal frictional wear.

The Terminator 2 reduces fan cycling by upto 70%, delivering unmatched service life and simplified maintenance. The two speed design reduces thermal stress on your radiator and engine components, while extending the service life of fan belts and belt idler pulleys.

TERMINATOR T2

Two Speed Clutch – eddy current drive (low speed)

Reduced maintenance cost over clutch lifetime : 70%* saving

Sealed bearing design : 1,000,000km+ product life-cycle

Service with a cost-effective Air Cartridge replacement :

Reduced cost and time (closest competitor analysis)



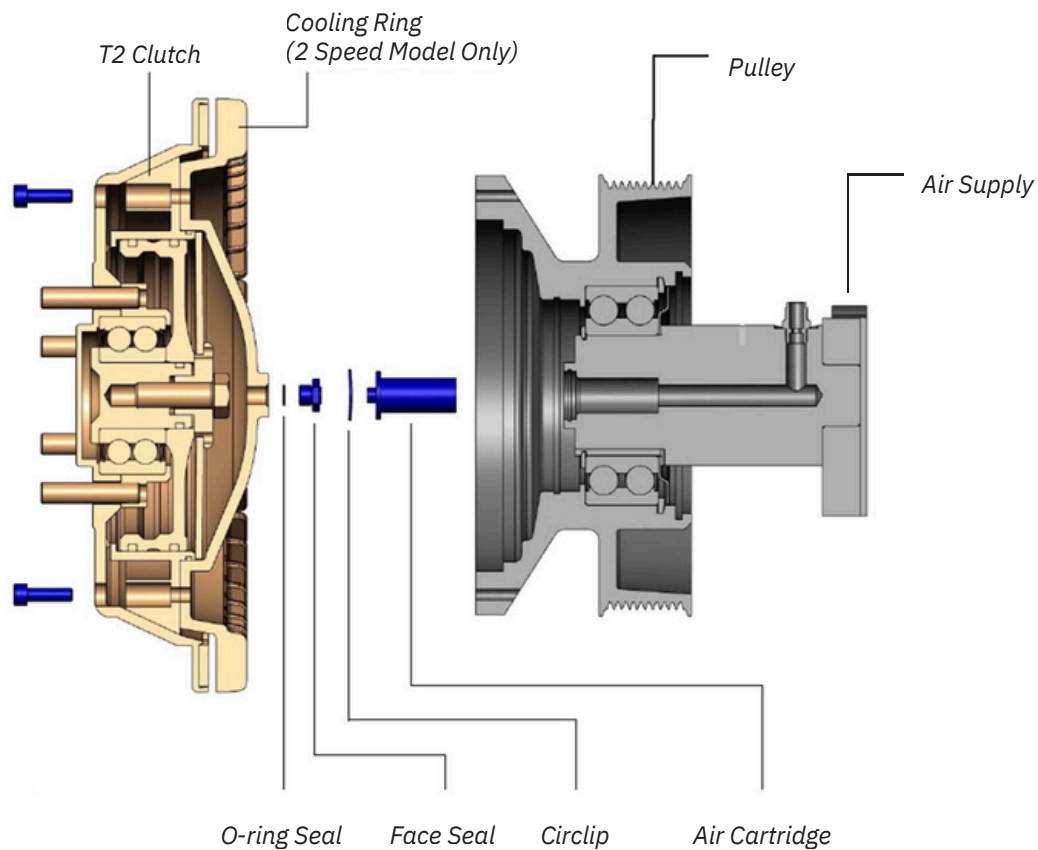

Terminator Fan Clutch Overview

T2 – two speed- **Current**

T1- Single speed - superseded by **T2**

The T2 model incorporates an array of permanent magnets that create the low-speed (eddy current) drive mode

Terminator Fan Clutch Warranty

Warranty is 12 Months unlimited Kilometers
Warranty claims must be submitted via online forms.

Clutch Friction Surface

T2 clutch features a patented low wearing Alloy Wedge friction material that will last the lifetime of the clutch and does not require replacement or maintenance, the complete fan clutch unit is replaced at end of life.

Air Supply

The **T2** fan clutches are engaged (on) when there is no air supplied to the clutch – “failsafe feature”.

The T2 is disengages (turns off) when air is applied to the clutch. The supply air requirements for Terminator 2 clutch are as follows;

- Supply air pressure 620– 690 kPa (90 - 100 PSI)
- Moisture trap required prior to control solenoid.
- Supply air plumbing must be leak free.

IMPORTANT

- Insufficient air pressure can cause the fan clutch to overheat due to slippage.
- Solenoid exhaust silencers must be kept clean to avoid slow clutch engagement.

Trouble Shooting Guide

<p>Issue 1: Air leaking from clutch</p>	<p>Solution:</p> <ol style="list-style-type: none"> 1. Inspect and fittings on hose ends – for air leaks and rectify as required. 2. Remove clutch from the pulley (refer to installation manual) and inspect the seal between the pulley and clutch and inspect the air cartridge. Replace with EB0230 Kit if worn.
<p>Cause:</p> <ol style="list-style-type: none"> 1. Air-line connection to clutch is faulty. 2. Leaking Air cartridge. 	
<p>Issue 2: Clutch not engaging / disengaging</p>	<p>Solution:</p> <ol style="list-style-type: none"> 1. Confirm wiring is as per OEM specification. 2. Fault check thermal switch, replace as required. 3. Clean solenoid exhaust or replace valve if faulty.
<p>Cause:</p> <ol style="list-style-type: none"> 1. Faulty electrical wiring. 2. Faulty thermal switch. 3. Faulty solenoid valve. 	
<p>Issue 3: Clutch cycles too frequently</p>	<p>Solution:</p> <ol style="list-style-type: none"> 1. Confirm wiring is as per OEM wiring. 2. Clutch engagements occurs at + 10°C above full open thermostat. 3. Ensure airside of cooling system is clean. 4. Top up coolant level as required. 5. Fault check thermal switch; replace if required.
<p>Cause:</p> <ol style="list-style-type: none"> 1. Electrical circuit short or incorrectly wired. 2. Temperature control setting is incorrect. 3. Obstruction to air flow through the radiator. 4. Low coolant level. 5. Faulty thermal switch. 	
<p>Issue 4: Clutch slipping on engagement</p>	<p>Solution:</p> <ol style="list-style-type: none"> 1. Check air supply system. *Note , 90-100 PSI operating range* 2. Some solenoids have a ‘slow’ release function, which is not recommended for a Terminator clutch. Replace with ‘quick’ release solenoid.
<p>Cause:</p> <ol style="list-style-type: none"> 1. Low air pressure. 2. Solenoid incompatible. 	
<p>Issue 5: Clutch face appears scorched / blistered</p>	<p>Solution:</p> <ol style="list-style-type: none"> 1. Check air supply system and fan function when air is applied 2. Level of overheating can damage internal bearings, contact Innotherm in an overheating event.
<p>Cause:</p> <ol style="list-style-type: none"> 1. Low air pressure (clutch slipping). 2. Solenoid not suitable (clutch slipping) 	
<p>Issue 6: Clutch engaged, engine running hot</p>	<p>Solution:</p> <ol style="list-style-type: none"> 1. Ensure airside of cooling system is clean. 2. Confirm OEM fan is installed. 3. Refer to OEM vehicle manual.
<p>Cause:</p> <ol style="list-style-type: none"> 1. Obstruction to air flow through the radiator. 2. Fan capacity not sufficient. 3. Cooling system problem. 	

Service Kits



Air Cartridge Service Kit - EB0230

- To ensure the fan drive is receiving clean, consistent air pressure, it is recommended the air cartridge is replaced every 400,000 km.

Kit available from InnoTherm – which include the following

Components:

- Air Cartridge x 1
- Circlip x 1
- Face Seal x 1
- Mounting Bolts x 8



T2 Clutch Replacement Kit - HKA4903

- Complete clutch assembly that replaces the T2 while using the T2 bracket and pulley. Time-efficient change over Expected EOL 1,300,000km

Components:

- Clutch (2" Spigot)
- Cartridge with snap-ring 87.016
- Nut M55
- Seal
- M6 Mounting Hardware
- TI-010 Service instructions

Service Instructions are available on our website- scan the QR code for more information



Service Kits

Air Cartridge Service Kit

- The air cartridge is designed to function as a wearing component and will need to be replaced once the plunger length is less than 4mm from the air cartridge face.
- Air cartridge life is influenced by the quality of the air supply (pressure and purity)
- It is recommended the air cartridge be checked at 300,000km and replace as required.
- The mating face seal must be replaced at the same time as a air cartridge.
- Air Cartridge Service Kit part number: **EB0230** (incl. air cartridge, face seal, circlip and o-ring)
- Refer to air cartridge service bulletin **EB0230** for further details.

Terminator Service Kit

- This kit provides the components to undertake a major refurbishment of a Terminator fan clutch
- This service kit includes; pulley bearings, air cartridge and seals.
- Refer to InnoTherm for further details.

Recommended Maintenance

Weekly Interval (or more frequently) ●

Drain the air filter water trap.

- Check for air leaks within the entire air supply circuit and rectify as necessary.
- Ensure air exhaust silencer is clean.

Monthly Interval (or more frequently)

- Check the air supply line for any sign of leaks.
- Check fan for damage. Out of balance fans will reduce fan clutch and pulley bearing life.

